

ME265: Thermal Engineering & Heat Transfer

Chapters
1. Energy Scenario
2. Thermodynamics
3. Mechanical Devices & Systems
4. Heat Transfer

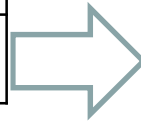

4.1 Introduction	
4.2 Conduction	
4.3 Convection	
4.4 Radiation	4.4.1 Radiation Fundamentals 4.4.2 View factors/Shape factor 4.4.3 Radiation exchange between surfaces
4.5 Heat Exchanger	4.5.1 Fundamentals 4.5.2 Analysis: LMTD method

4.5- HX Analysis

□ Two design Scenario:

1) Specified:

- the temperature change in a fluid stream, and
- the mass flow rate.

Required:

- to select a heat exchanger: type, size

2) Specified:

- the heat exchanger type and size,
- fluid mass flow rate,
- inlet temperatures.

Required:

- the outlet temperatures and heat transfer rate.

4.5- HX Analysis

□ Two design Scenario:

1) Specified:

- the temperature change in a fluid stream, and
- the mass flow rate.

Required:

- to select a heat exchanger: type, size

2) Specified:

- the heat exchanger type and size,
- fluid mass flow rate,
- inlet temperatures.

Required:

- the outlet temperatures and heat transfer rate.

□ Two methods are used in the analysis of HXs:

- the log mean temperature difference (LMTD)
 - best suited for the task #1,
- the effectiveness, ϵ -NTU method
 - best suited for the task #2.

4.5- HX Analysis

Assumptions:

- steady-flow
- kinetic and potential energy changes are negligible
- the specific heat of a fluid is constant
- axial heat conduction along the tube is negligible
- the outer surface of the heat exchanger is perfectly insulated.

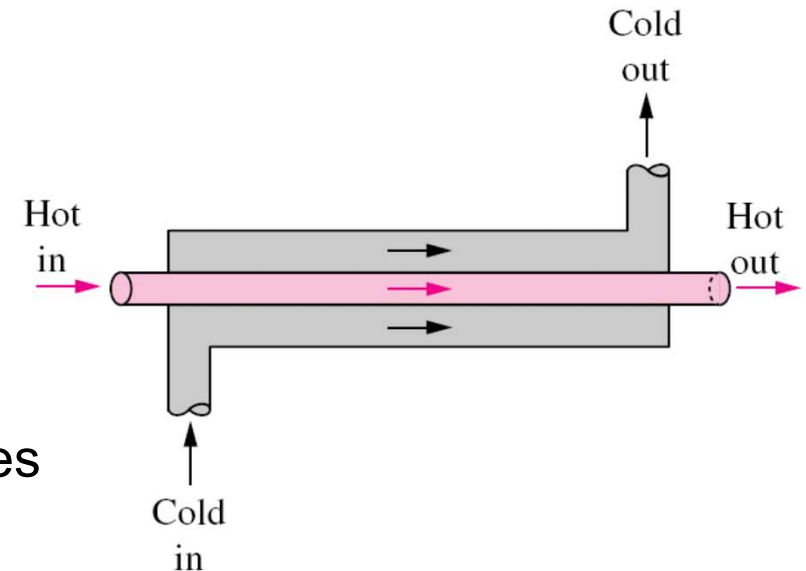

4.5- HX Analysis

□ LMTD Method: Parallel flow HX

- Energy balance:

$$\begin{cases} \delta\dot{Q} = -\dot{m}_h c_{ph} dT_h \\ \delta\dot{Q} = \dot{m}_c c_{pc} dT_c \end{cases}$$



$$\begin{cases} dT_h = -\frac{\delta\dot{Q}}{\dot{m}_h c_{ph}} \\ dT_c = \frac{\delta\dot{Q}}{\dot{m}_c c_{pc}} \end{cases}$$

- Therefore:

$$dT_h - dT_c = d(T_h - T_c) = -\delta\dot{Q} \left(\frac{1}{\dot{m}_h c_{ph}} + \frac{1}{\dot{m}_c c_{pc}} \right) \dots\dots(5.6)$$

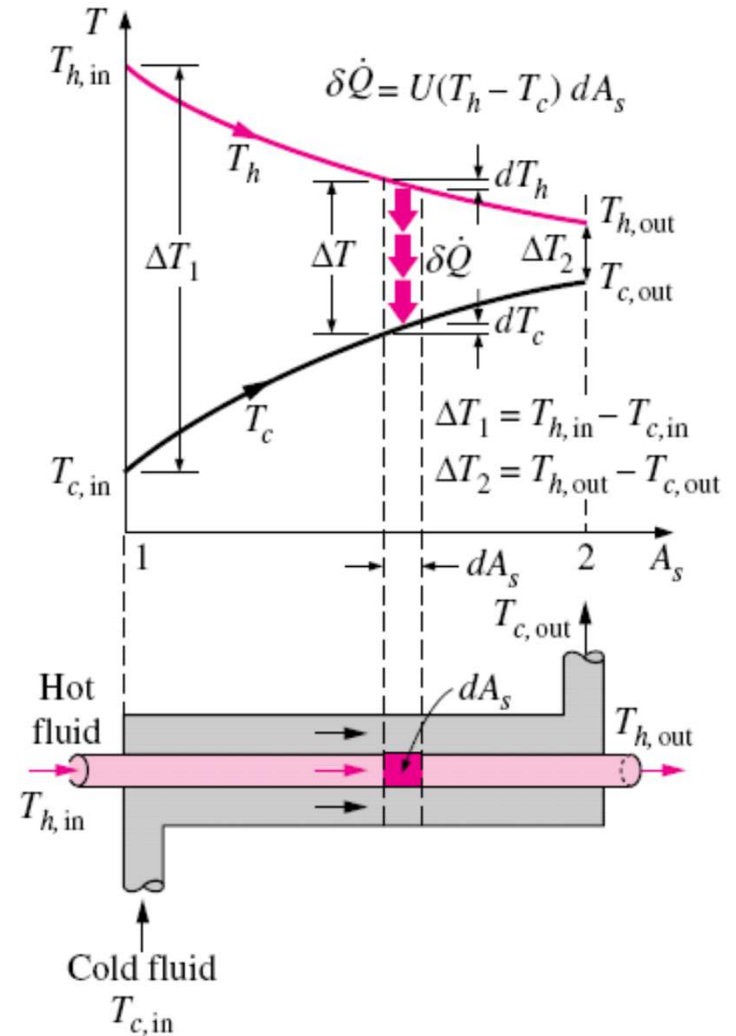

4.5- HX Analysis

□ LMTD Method: Parallel flow HX

$$d(T_h - T_c) = -\delta\dot{Q} \left(\frac{1}{\dot{m}_h c_{ph}} + \frac{1}{\dot{m}_c c_{pc}} \right) \dots\dots(5.6)$$

Substituting $\delta\dot{Q} = U(T_h - T_c) dA_s$

$$\frac{d(T_h - T_c)}{T_h - T_c} = -U dA_s \left(\frac{1}{\dot{m}_h c_{ph}} + \frac{1}{\dot{m}_c c_{pc}} \right) \dots\dots(5.7)$$

By integrating, we get:

$$\ln \frac{T_{h,out} - T_{c,out}}{T_{h,in} - T_{c,in}} = -UA_s \left(\frac{1}{\dot{m}_h c_{ph}} + \frac{1}{\dot{m}_c c_{pc}} \right) \dots\dots(5.8)$$

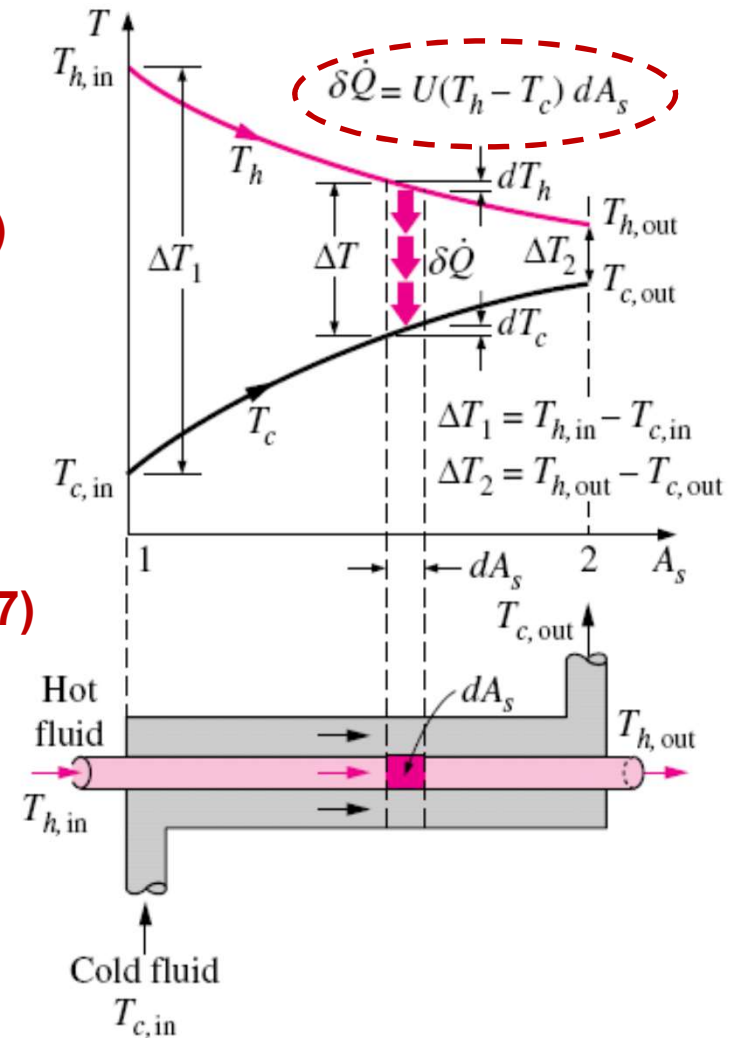

4.5- HX Analysis

5.2.1 LMTD Method: Parallel flow HX

$$\ln \frac{T_{h,out} - T_{c,out}}{T_{h,in} - T_{c,in}} = -UA_s \left(\frac{1}{\dot{m}_h c_{ph}} + \frac{1}{\dot{m}_c c_{pc}} \right) \dots\dots(5.8)$$

$$\begin{aligned} \dot{Q} &= \dot{m}_h c_{ph} (T_{h,in} - T_{h,out}) \\ \Rightarrow \frac{1}{\dot{m}_h c_{ph}} &= \frac{T_{h,in} - T_{h,out}}{\dot{Q}} \end{aligned}$$

$$\begin{aligned} \dot{Q} &= \dot{m}_c c_{pc} (T_{c,out} - T_{c,in}) \\ \Rightarrow \frac{1}{\dot{m}_c c_{pc}} &= \frac{T_{c,out} - T_{c,in}}{\dot{Q}} \end{aligned}$$

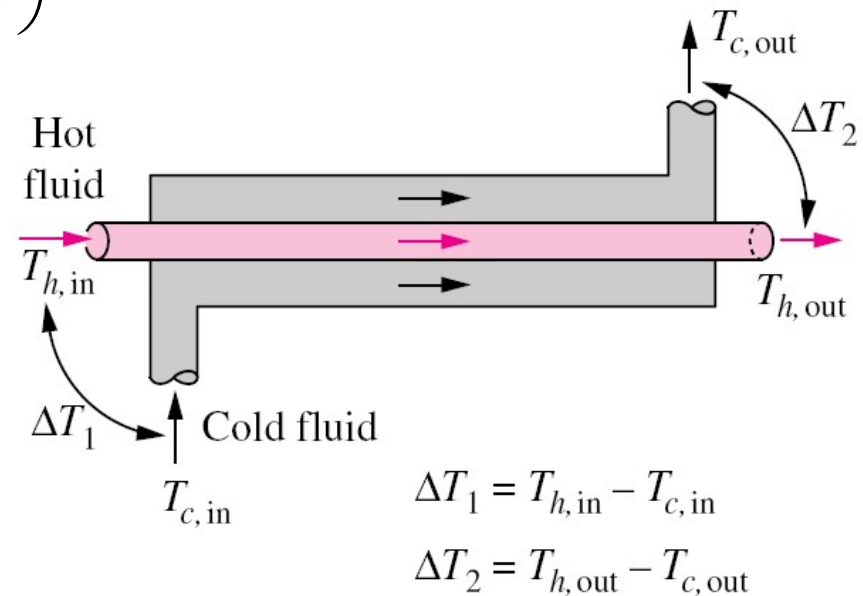

From Eq (5.8) and using $\Delta T_1 = T_{h,in} - T_{c,in}$ and $\Delta T_2 = T_{h,out} - T_{c,out}$

$$\dot{Q} = UA_s \Delta T_{lm} \dots\dots(5.9) \quad \text{Where, } \Delta T_{lm} = \frac{\Delta T_1 - \Delta T_2}{\ln(\Delta T_1 / \Delta T_2)}$$

ΔT_{lm} is the log mean temperature difference (LMTD)

4.5- HX Analysis

□ LMTD Method: Counter-flow HX

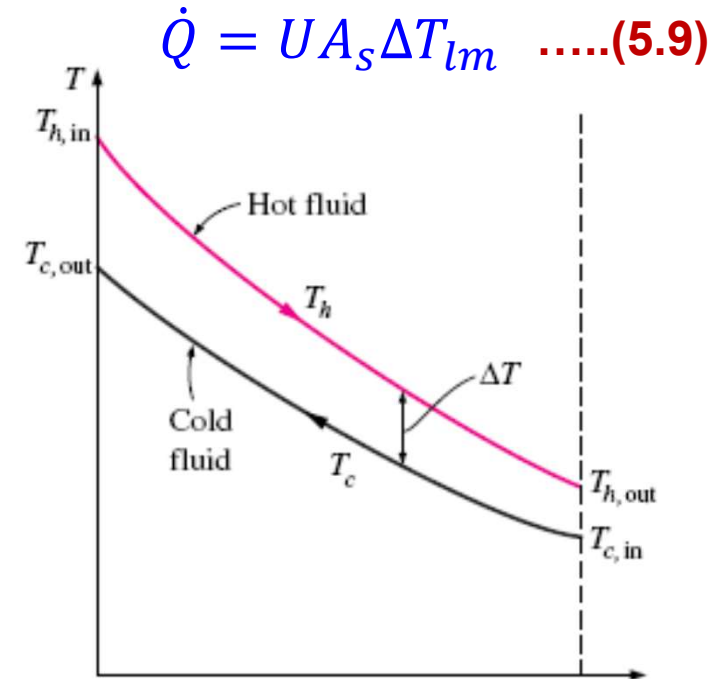
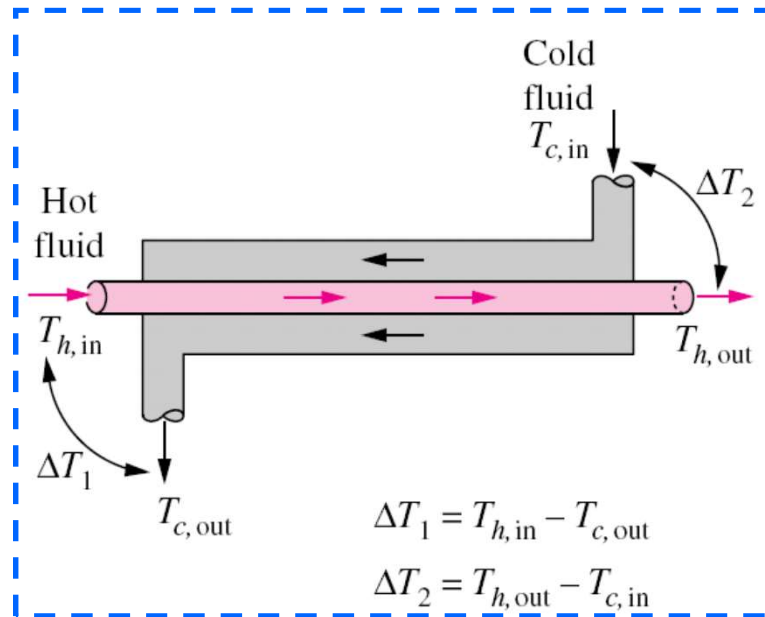

- The LMTD for parallel-flow HX is applicable for a counter-flow HX.
- ΔT_1 and ΔT_2 are expressed differently as shown.
- $\Delta T_{Im, CF} > \Delta T_{Im, PF}$
- Therefore, a smaller A_s (a smaller HX) is needed to achieve a specified heat transfer rate in a counter-flow HX.

4.5- HX Analysis

□ LMTD Method:

- The LMTD relation developed is limited to parallel-flow and counter-flow HXs only.
- For the analysis of *cross-flow* and *multipass shell-and-tube HXs*, it is convenient to express the LMTD as

$$\Delta T_{lm} = F \Delta T_{lm,CF} \quad \dots(5.10)$$

- F is the correction factor, and $\Delta T_{lm,CF}$ is the log mean temperature for counter-flow case.

4.5- HX Analysis

5.2.1 LMTD Method:

$$\Delta T_{lm} = F \Delta T_{lm,CF} \quad \dots(5.10)$$

F Charts for Shell-and-Tube HXs

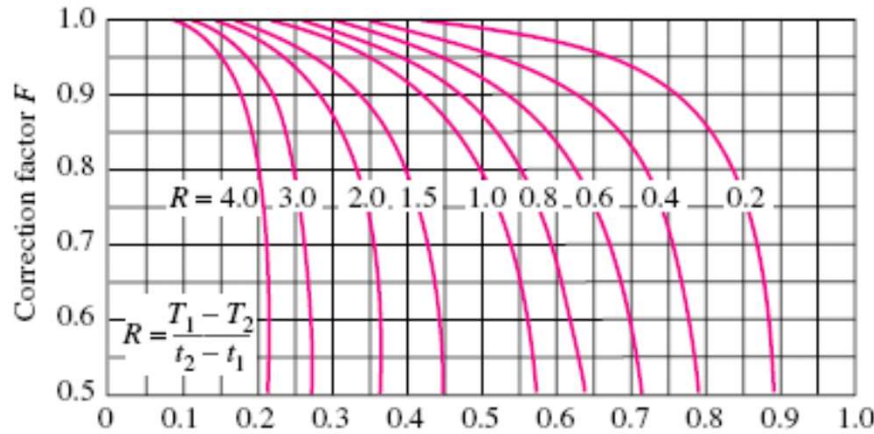

(a) One-shell pass and 2, 4, 6, etc. (any multiple of 2), tube passes

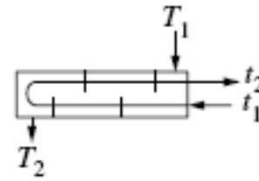

$$P = \frac{t_2 - t_1}{T_1 - t_1}$$

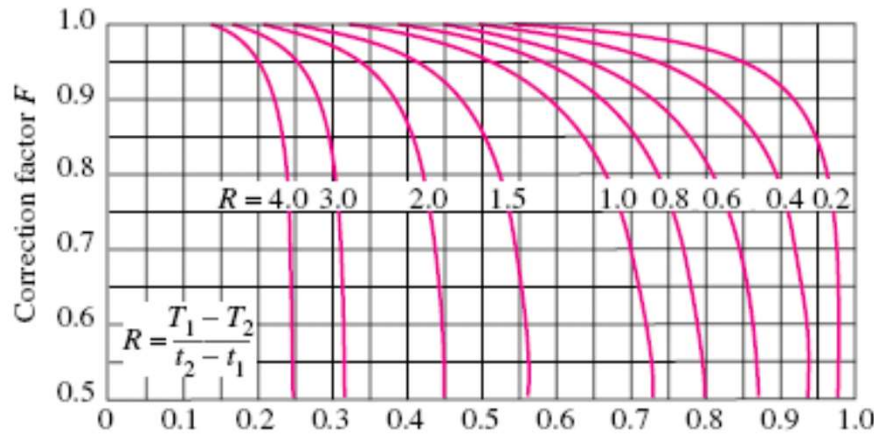

(b) Two-shell passes and 4, 8, 12, etc. (any multiple of 4), tube passes

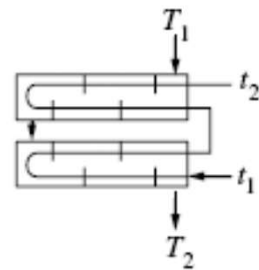

$$P = \frac{t_2 - t_1}{T_1 - t_1}$$

4.5- HX Analysis

5.2.1 LMTD Method:

$$\Delta T_{lm} = F \Delta T_{lm,CF} \quad \dots(5.10)$$

F Charts for Cross-Flow HXs

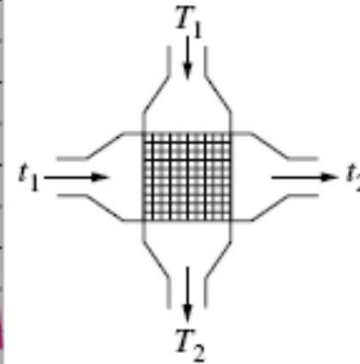
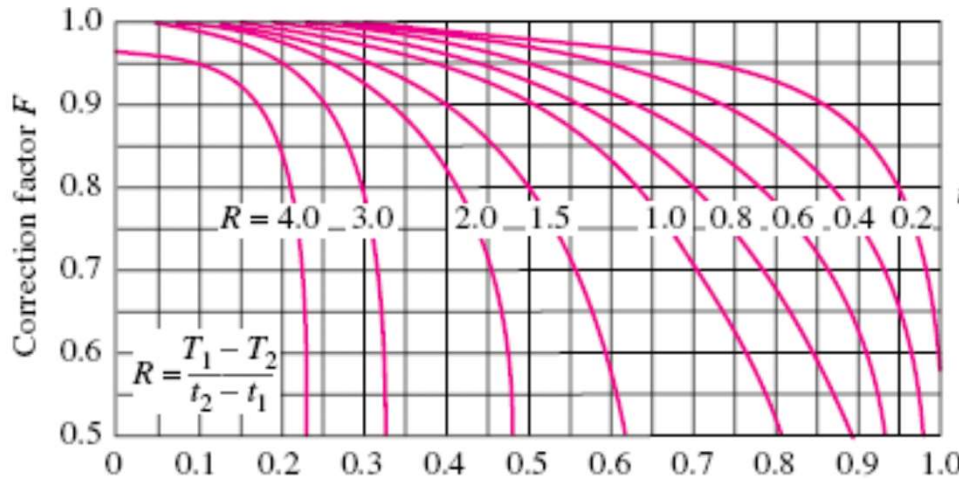

$$P = \frac{t_2 - t_1}{T_1 - t_1}$$

(c) Single-pass cross-flow with both fluids *unmixed*

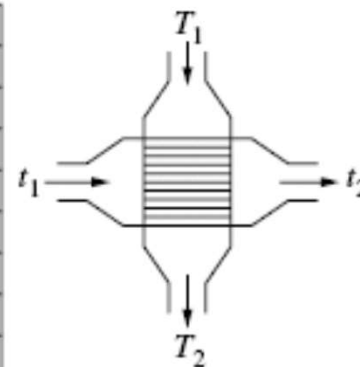
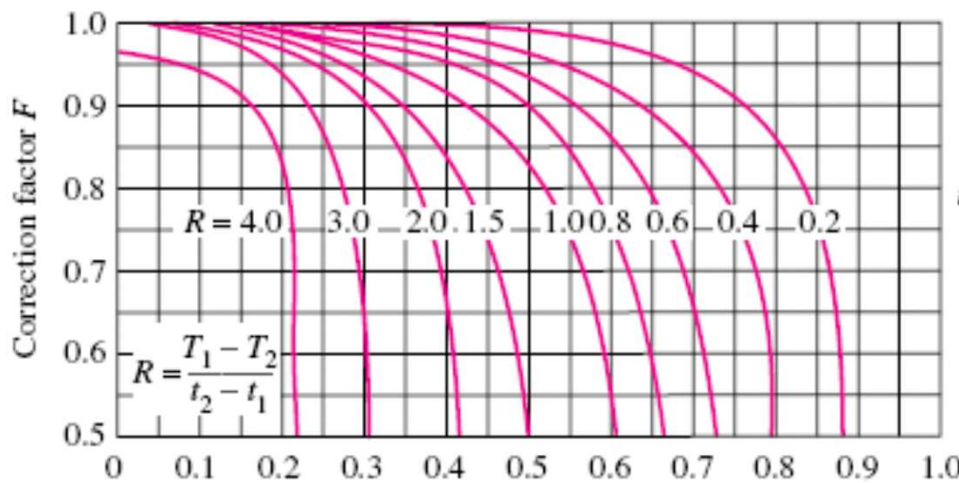

$$P = \frac{t_2 - t_1}{T_1 - t_1}$$

(d) Single-pass cross-flow with one fluid *mixed* and the other *unmixed*

4.5- HX Analysis

EP# 5.2 Cengel et al. Example Prob: 11-2

A counter-flow double-pipe heat exchanger is to heat water from 20°C to 80°C at a rate of 1.2 kg/s . The heating is to be accomplished by geothermal water available at 160°C at a mass flow rate of 2 kg/s . The inner tube is thin-walled and has a diameter of 1.5 cm . If the overall heat transfer coefficient of the heat exchanger is $640\text{ W/m}^2\text{C}$, determine the length of the heat exchanger required to achieve the desired heating.

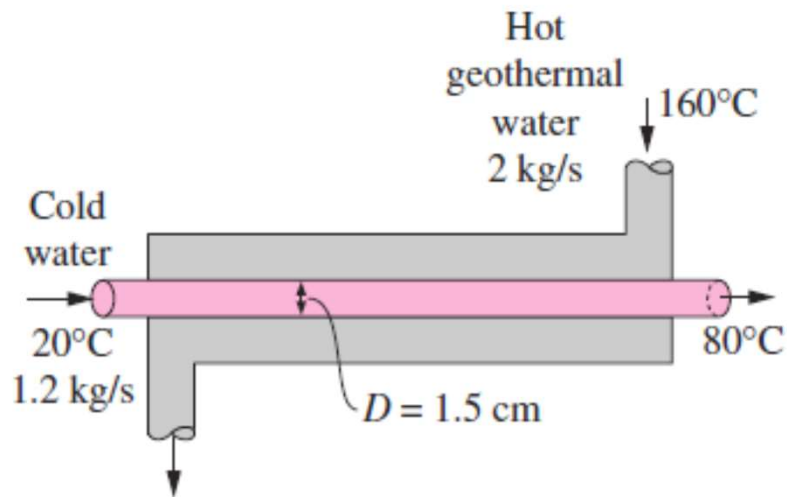

4.5- HX Analysis

EP# 5.3 Cengel et al. Example Prob: 11-2

A 2-shell passes and 4-tube passes heat exchanger is used to heat glycerin from 20°C to 50°C by hot water, which enters the thin-walled 2-cm-diameter tubes at 80°C and leaves at 40°C . The total length of the tubes in the heat exchanger is 60 m. The convection heat transfer coefficient is $25\text{ W/m}^2\text{C}$ on the glycerin (shell) side and $160\text{ W/m}^2\text{C}$ on the water (tube) side. Determine the rate of heat transfer in the heat exchanger (*a*) before any fouling occurs and (*b*) after fouling with a fouling factor of $0.0006\text{ m}^2\text{C/W}$ occurs on the outer surfaces of the tubes.

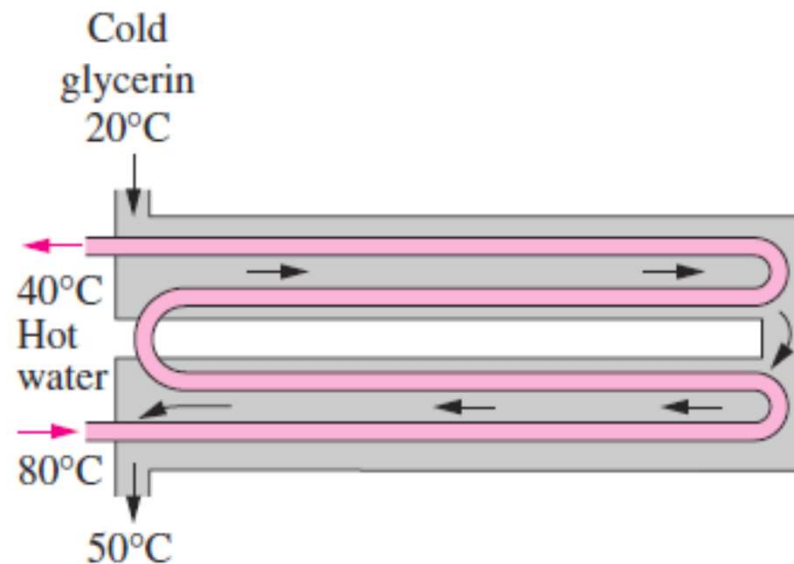

4.5- HX Analysis

□ Selection of Heat Exchangers

- An engineer going through catalogs of heat exchanger manufacturers will be overwhelmed by the type and number of readily available off-the-shelf heat exchangers.
- The proper selection depends on several factors:
 - heat transfer rate
 - cost
 - procurement, maintenance, and power.
 - pumping power,
 - size and weight,
 - Type,
 - Materials,
 - miscellaneous (leak-tight, safety and reliability, Quietness).