

ME 223
**ELEMENTS OF FLUID MECHANICS
& MACHINERY**

TURBOMACHINES

LECTURE 4

MD. Rakib Hossain

Lecturer

Department of Mechanical Engineering, BUET.

TURBOMACHINES

- ❖ Machines which deliver liquids are simply called **pumps**, but if gases are involved, three different terms are in use, depending upon the pressure rise achieved
- ❖ If the pressure rise is very **small**(a few inches of water), a gas pump is called a **fan**; **upto 1 atm**, it is usually called a **blower**, and **above 1 atm** it is commonly termed a **compressor**
- ❖ There are two basic types of pumps: **positive-displacement** and **dynamic or momentum change pumps**

POSITIVE-DISPLACEMENT PUMPS

- ❖ Positive-displacement pumps **force** the fluid along by volume changes. A cavity opens, and the fluid is admitted through an inlet. The cavity then closes, and the fluid is squeezed through an outlet. **Ex:** reciprocating pumps, vane pumps, screw pumps gear pumps etc
- ❖ These pumps deliver a pulsating or periodic flow as the cavity volume opens, traps and squeezes the fluid. Their great **advantage** is the delivery of any fluid **regardless of the viscosity**
- ❖ They develop **immense pressure** if the outlet is shut down for any reason. Complete shut down will damage the pump if no pressure relief valve is used

POSITIVE-DISPLACEMENT PUMPS

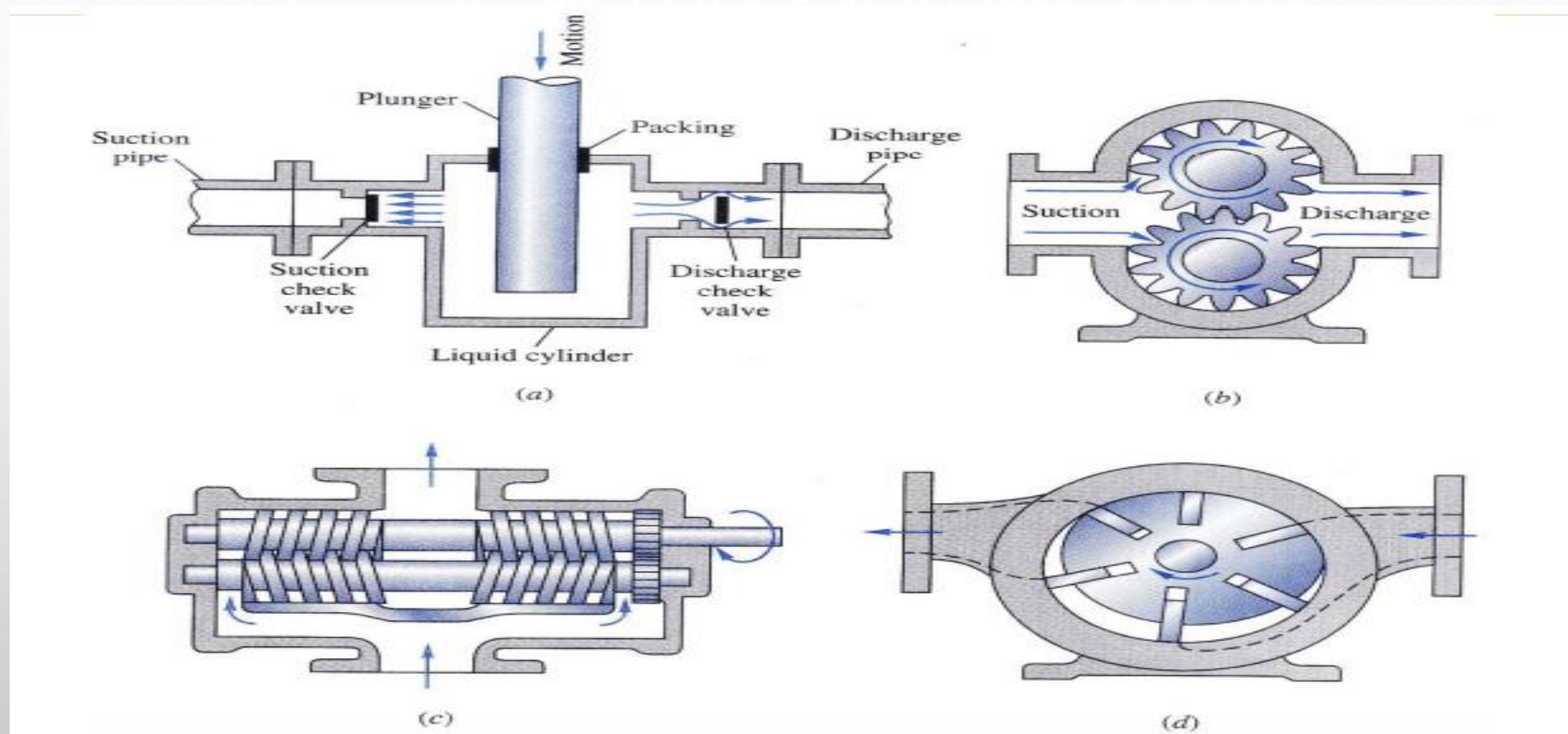

Schematic diagrams of (a) reciprocating plunger pump (b) External gear pump (c) Double screw pump (d) Vane pump

DYNAMIC PUMPS

- ❖ Dynamic pumps simply add momentum to the fluid by means of **fast-moving blades** or vanes or certain special designs. There is **no closed** volume: the fluid increases momentum while moving through open passages and then converts its high velocity to a pressure increase by exiting into a diffuser section

Dynamic pumps can be classified as follows:

- I. **Rotary:** Centrifugal or radial flow, Axial flow, Mixed flow
- II. **Special designs:** Jet pump or ejector, Electro magnetic pumps for liquid metals, Fluid-actuated: gas-lift or hydraulic-ram

We shall focus on the rotary designs, sometimes called Rotodynamic Pumps

POSITIVE DISPLACEMENT VS. DYNAMIC PUMPS

- ❖ **Dynamic pumps** generally provide a higher flow rate than the **positive-displacement pumps** and a much steadier discharge but are ineffective in handling high-viscosity liquids
- ❖ **Dynamic pumps** also generally need priming; i.e., if they are filled with gas they cannot suck liquid from below into their inlet. The Positive-displacement Pump, on the other hand, is usually self-priming

POSITIVE DISPLACEMENT VS. DYNAMIC PUMPS

- ❖ A **dynamic pump** can provide very high flow rates (up to 300,000gal/min) but usually with moderate pressure rises (a few atmospheres). In contrast, a **Positive-displacement Pump** can operate up to very high pressures (300 atm) but typically produces low flow rates (100gal/min)

CENTRIFUGAL PUMPS

- ❖ A centrifugal pump consists of two principal parts: an **impeller**, which imparts a rotary motion to the liquid, and the **pump housing, or casing**, which directs the liquid into the impeller region and transports it away under a higher pressure

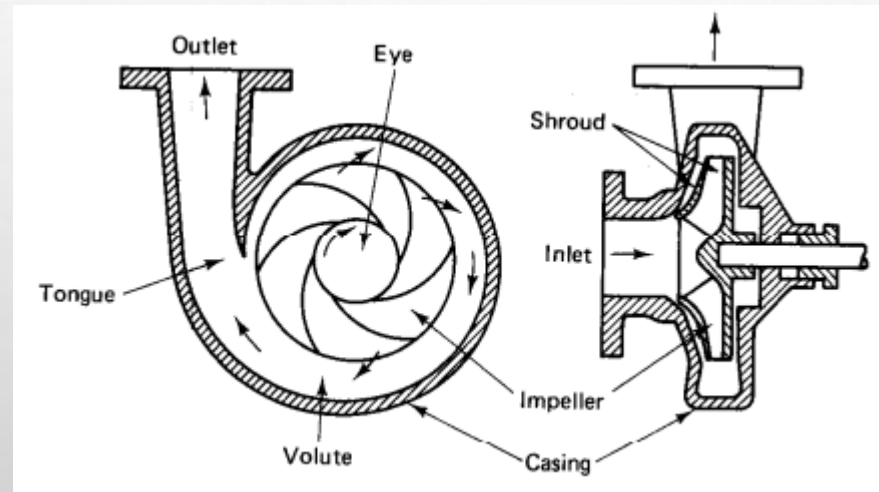

CENTRIFUGAL PUMPS

- ❖ In a typical single-suction radial flow centrifugal pump, the **impeller** is mounted on a shaft and is often driven by an **electric motor**. The casing includes the suction and discharge nozzles and houses the impeller assembly
- ❖ The portion of the casing surrounding the impeller is termed the **volute**. Liquid enters through the suction nozzle to the **impeller eye** and travels along the shroud, developing a rotary motion due to the impeller vanes. It leaves the volute casing peripherally at a higher pressure through the discharge nozzle